

Energy-Efficient Water Heating

The next time you pay your utility bill, try one simple calculation. Divide the total amount by seven. The result is the amount you spend to heat your water. (If you receive separate utility bills for gas and electricity, use the gas bill for this calculation if you have a gas water heater; use the electric bill if you have an electric water heater.)

Of course, you may think this cost is a small price to pay for the convenience of a hot shower. But during the course of a year, this cost adds up. And when you consider that 95 million households in this country pay the same percentage, it is easy to see how much money—and energy—is used to heat water.

Several measures can help you decrease water-heating costs in your home. Some specific actions include reducing the amount of hot water used, making your water-heating system more energy efficient, and using off-peak power to heat water.

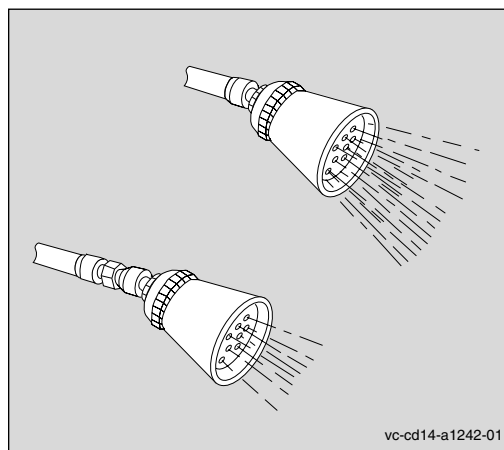

Although a low-flow showerhead (bottom) delivers slightly less water than a standard showerhead (top), the spray can still be invigorating.

Reducing the Amount of Hot Water Used

Generally, four destination points in the home are recognized as end uses for hot water: faucets, showers, dishwashers, and washing machines. Now, you do not have to take cold showers, dine on dirty dishes, or wear dirty clothes to reduce your hot-water consumption. Less radical measures are available that will be virtually unnoticeable once you apply them.

Faucets and Showers

Simply repairing leaks in faucets and showers can save hot water. A leak of one drip per second can cost \$1 per month, yet could be repaired in a few minutes for less than that. And some apparently insignificant steps, when practiced routinely at your household, could have significant results. For example, turning the hot-water faucet off while shaving or brushing your teeth, as opposed to letting the water run, can also reduce water-heating costs. Another option is limiting the amount of time you spend in the shower.

Other actions may require a small investment of time and money. Installing low-flow showerheads and faucet aerators can save significant amounts of hot water. Low-flow showerheads can reduce hot-water consumption for bathing by 30%, yet still provide a strong, invigorating spray. Faucet aerators, when applied in commercial and multifamily buildings where water is constantly circulated, can also reduce water-heating energy consumption.

Older showerheads deliver 4 to 5 gallons (15.1 to 18.9 liters) of water per minute. However, the Energy Policy Act of 1992



Turning the hot-water faucet off while shaving or brushing your teeth, as opposed to letting the water run, can reduce water-heating costs.

sets maximum water flow rates at 2.5 gallons (9.5 liters) per minute at a standard residential water pressure of 80 pounds per square inch (552 kilopascals).

A quick test can help you determine if your shower is a good candidate for a showerhead replacement. Turn on the shower to the normal pressure you use, hold a bucket that has been marked in gallon increments under the spray, and time how many seconds it takes to fill the bucket to the 1-gallon (3.8-liter) mark. If it takes less than 20 seconds, you could benefit from a low-flow showerhead. A top-quality, low-flow showerhead will cost \$10 to \$20 and pay for itself in energy saved within 4 months. Lower quality showerheads may simply restrict water flow, which often results in poor performance.

Because of the different uses of bathroom and kitchen faucets, you may need to have different water flow rates in each location. For bathroom faucets, aerators that deliver 0.5 to 1 gallon (1.9 to 3.8 liters) of water per minute may be sufficient. Kitchen faucets may require a higher flow rate of 2 to 4 gallons (7.6 to 15.1 liters) per minute if you regularly fill the sink for washing dishes. On the other hand, if you tend to let the water run when washing dishes, the lower flow rate of 0.5 to 1 gallon per minute may be more appropriate. Some aerators come with shut-off valves that allow you to stop the flow of water without affecting the temperature.

Automatic Dishwashers

A relatively common assumption is that washing dishes by hand saves hot water. However, washing dishes by hand several times a day could be more expensive than operating some automatic dishwashers. If properly used, an efficient dishwasher can consume less energy than washing dishes by hand, particularly when you only operate the dishwasher with full loads.

The biggest cost of operating a dishwasher comes from the energy required to heat the water before it ever makes it to the machine. Heating water for an automatic dishwasher can represent about 80% of the energy required to run this appliance.

Average dishwashers use 8 to 14 gallons (30.3 to 53 liters) of water for a complete wash cycle and require a water temperature of 140° F (60° C) for optimum cleaning. But setting your water heater so high could result in excessive standby heat loss. This type of heat loss occurs because water is constantly heated in the storage tank, even when no hot water is used. Furthermore, a water heater temperature of 120° F (48.9° C) is sufficient for other uses of hot water in the home. The question, then, is must you give up effective cleaning for hot-water energy savings? The answer is no.

A “booster” heater can increase the temperature of the water entering the dishwasher to the 140° F recommended for cleaning. Some dishwashers have built-in boosters that will automatically raise the water temperature, while others require manual selection before the wash cycle begins. A booster heater can add about \$30 to the cost of a new dishwasher but should pay for itself in water-heating energy savings in about 1 year if you also lower your water heater temperature. Reducing the water heater temperature is not advisable, however, if your dishwasher does not have a booster heater.

Another feature that reduces hot-water use in dishwashers is the availability of cycle selections. Shorter cycles require less water, thereby reducing the energy cost.

The most efficient dishwasher currently on the market can cost half as much to operate as the most inefficient model. If you are planning to purchase a new dishwasher, check the EnergyGuide labels and compare the approximate yearly energy costs among brands. Dishwashers fall into one of two categories—compact capacity or standard capacity. Although compact-capacity dishwashers may appear to be more energy efficient, they hold fewer dishes and may force you to use the appliance more frequently than you would use a standard-capacity model. In this case, your energy costs could be higher than with the standard-capacity dishwasher.

An efficient automatic dishwasher can consume less energy than washing dishes by hand, particularly when you only operate the dishwasher with full loads.

Unlike dishwashers, washing machines do not require a minimum temperature for optimum cleaning.

Washing Machines

Like dishwashers, much of the cost—up to 90%—of operating washing machines is associated with the energy needed to heat the water. Unlike dishwashers, washing machines do not require a minimum temperature for optimum cleaning. Either cold or warm water can be used for washing most laundry loads; cold water is always sufficient for rinsing. Make sure you follow the cold-water washing instructions for your particular laundry detergent. Washing only full loads is another good rule of thumb for reducing hot-water consumption in clothes washers.

As you would for dishwashers, consult the EnergyGuide labels when shopping for a new washing machine. Inefficient washing machines can cost three times as much to operate as efficient machines. Select a machine that allows you to adjust the water temperature and water levels for the size of the load. Also, front-loading machines use less water and, consequently, less energy than top loaders. However, in this country, front loaders are not as widely available as top loaders. Keep in mind that the capacity of front loaders may be smaller than that of most top-loading machines.

Smaller capacity washing machines often have better EnergyGuide ratings. However, a reduced capacity might cause you to increase the number of loads you wash and possibly increase your energy costs.

Faucets, showerheads, dishwashers, and washing machines are only destination points for hot water in your home. The journey of your hot water before it reaches these outlets can be fraught with opportunities for energy losses. Fortunately, you can reduce the incidence of water heat loss from the point of departure to the point of arrival by applying a few basic measures.

Increasing Water-Heating System Efficiency

Reducing hot-water usage is primarily a matter of common sense and exerting a little extra effort to not be wasteful. Once you have applied a few simple, low-cost measures for reducing hot-water consumption, you may want to consider water-heating system improvements if you wish to further reduce your energy bill.

Lower Your Water Heater Thermostat

One simple step for reducing water-heating energy costs is lowering the thermostat setting on your water heater. Although some manufacturers set water heaters at 140° F (60° C), 120° F (48.9° C) is satisfactory for most household needs. Furthermore, when heated to 140° F, water can pose a safety hazard (i.e., scalding). For each 10° F (5.6° C) reduction in water temperature, water-heating energy consumption can be reduced 3% to 5%.

If your dishwasher does not have a booster heater, lowering the water-heating temperature is not recommended. Also, many dishwasher detergents are formulated to clean effectively at 140° F and may not perform adequately at lower temperatures. (See previous discussion on Automatic Dishwashers.)

On gas water heaters, thermostats are usually visible. Electric water heaters, on the other hand, may have thermostats positioned behind screw-on plates. As a safety precaution, shut off electric current to the water heater before removing the plates. Keep in mind that electric water heaters may have two thermostats to adjust—one each for the upper and lower heating elements—and adjusting these is tricky. Talk to your local water-heating professional for help with this.

When you plan to be away from home for an extended period of time (at least 3 days), turning the water heater thermostat down to the lowest setting, or even turning the heater off completely, can help you achieve additional savings. Be sure you know how to relight the pilot light on your gas heater, though, before you turn it off.

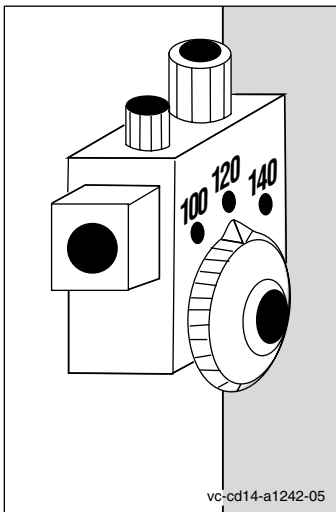

Setting the thermostat on your water heater to 120° F, which is sufficient for most household needs, is an energy-saving measure you may wish to consider.

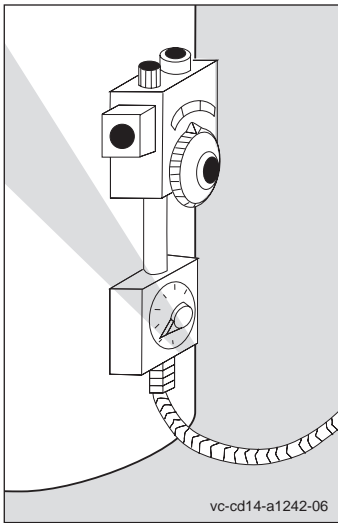

Timers that automatically turn your water heater off and on are a good energy-saving option if you have an electric water heater.

Install a Timer and Heat Traps

Another possibility for electric water heaters is installing a timer that can automatically turn the heater off at night and on in the morning. At a \$30 selling price and a do-it-yourself installation, a simple timer may pay for itself in energy saved in about 1 year. More expensive, multisetting timers are also available. Timers for gas water heaters are not as useful or cost effective as those designed for electric water heaters. This is because the pilot light supplies some heat during the night, offsetting some of the energy savings achieved by using the timer.

If heat traps were not initially installed with your water heater, adding them is another way of reducing water-heating energy loss. Heat traps, or one-way valves, allow water to flow into the tank and prevent unwanted hot-water flow out of the tank. Heat traps cost about \$30, but they may require professional installation, which could be expensive. However, if installed at the same time as a new water heater, heat traps are much more cost effective. Most new water heater models have factory installed traps, saving you the time and expense of installing one yourself.

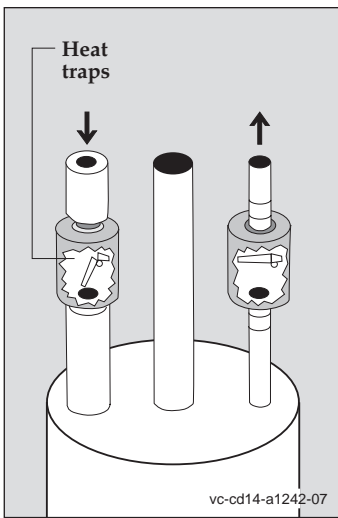

Heat traps, or one-way valves, can control the flow of water into and out of your storage tank.

Insulate Hot-Water Pipes and the Storage Tank

When you turn on a hot-water faucet during cold weather, it may take several seconds for the water to become hot. This happens because the water travels through pipes from the water heater to the faucet, and some of the pipes may pass through unheated sections of the house, such as the basement. As a result, the hot water loses some of its heat to the surrounding space.

This heat loss can be reduced by insulating hot water pipes wherever they are accessible—especially in unheated areas. Use quality pipe insulation wrap, or neatly taped strips of fiberglass insulation around the pipes. Eventually the water will cool, but it will remain warmer much longer inside insulated pipes.

Insulating your water-heater storage tank is a fairly simple and inexpensive improvement that can help maintain the water temperature at the thermostat setting. Some newer models of water heaters are

well insulated and do not need an added layer, but a heater that is warm to the touch needs additional insulation.

Easy-to-install, pre-cut blankets (or jackets) for electric water heaters are widely available and range in cost from \$10 to \$20. Your local utility company may offer them at a lower price, give you a rebate, or even install them at no cost. When properly installed, a water heater blanket on an electric water heater will pay for itself in energy saved within 1 year. Installation is more difficult on gas- and oil-fired heaters. Ask your local furnace installer for instructions.

If your water heater is at least 7 years old, you should carefully evaluate your water-heating needs and investigate the types of heaters that could replace your current one. Although most water heaters last 10 to 15 years, early investigation and timely replacement can ensure a wiser purchase. For more information on the types of water heaters now available, contact the Energy Efficiency and Renewable Energy Clearinghouse (EREC—see Source List).

Using Off-Peak Power to Heat Water

Most consumers use more hot water in the evenings and mornings than at other times of the day. For those who have an electric water heater, this usage contributes to the electric utility company's "peak load," or the largest amount of power demand that they have to meet on a daily basis. Some utilities are required to offer their customers "time of use" rates that vary according to the demand on their system. Lower rates may be charged at "off-peak" times and higher rates at "on-peak" times. You may be able to lower your electric bills if you can take advantage of these rate schedules. Check with your local electric utility to find out if it offers time-of-use rates for residential customers, and if so, what the rate schedules are. Some utilities even offer incentives for customers who allow their utility to install control devices that shut off electric water heaters during peak demand periods.

Simple Actions, Big Results

Some ways to save on water-heating bills require greater financial investments than others. You may wish to consider the no- or low-cost options before making large purchases. Also allow for circumstances that may be unique to your household when deciding on the appropriate options (e.g., a small-capacity washing

machine could meet the needs of a one-person household efficiently).

Although it is not feasible to eliminate water heating in your home, it is possible to substantially reduce water-heating costs without sacrificing comfort and convenience. The tips in this publication can help decrease your costs for heating water.

Installing an Insulation Blanket on an Electric Water Heater

Note: Installation is more difficult on gas- and oil-fired heaters. Ask your local furnace installer for instructions.

1. Cut the tank top insulation to fit around the piping in the top of the tank. Tape the cut section closed after the top has been installed.
2. Fold the corners of the tank top insulation down and tape to the sides of the tank (Figure 1).
3. Position the insulating blanket around the circumference of the tank. For ease of installation, position the blanket so that the ends do not come together over the access panels in the side of the tank. Some tanks have only one access panel.
4. Secure the blanket in place with the belts provided. Position the belts so they do not go over the access panels (Figure 2). Belts should fit snugly over the blanket but not compress it more than 15% to 20% of its thickness. The installation is easier with two people. If working alone, use tape to hold the blanket to the top until you get the belts into position.
5. If your water heater has the temperature/pressure relief valve and the overflow pipe on the side of the tank instead of on the top, install the blanket so these items are outside of the blanket. Depending on the piping arrangement and location, you may need to compress, or even cut, the blanket.
6. Locate the four corners of the access panel(s). Make an x-shaped cut in the insulating blanket from corner to corner of each access panel (Figure 3).
7. Fold the triangular flaps produced by the cuts underneath the insulating blanket (Figure 4). Repeat steps 6 and 7 for the rating/instruction plate.
8. The blanket must not be installed on a leaking tank.

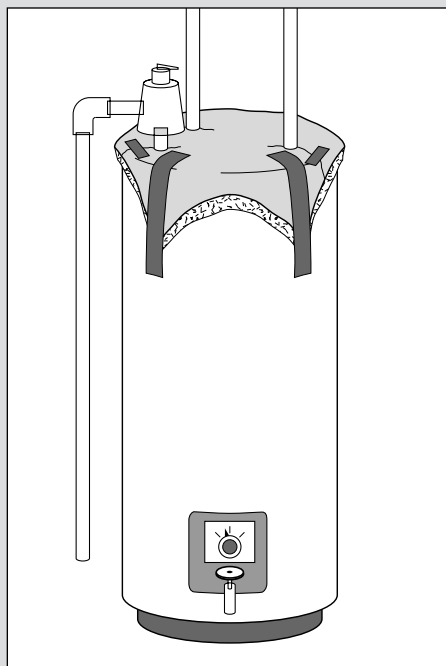

1

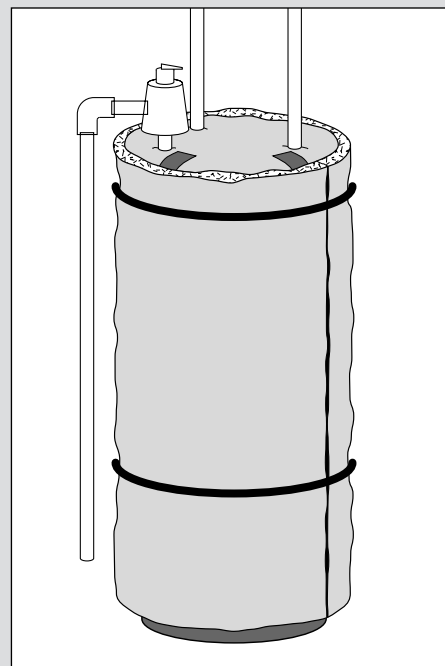

2

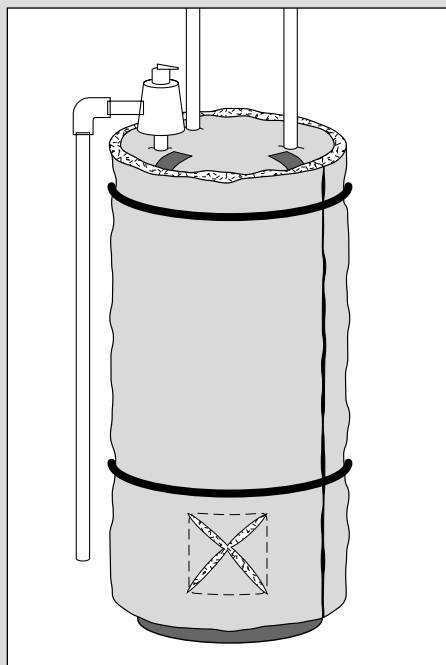

3

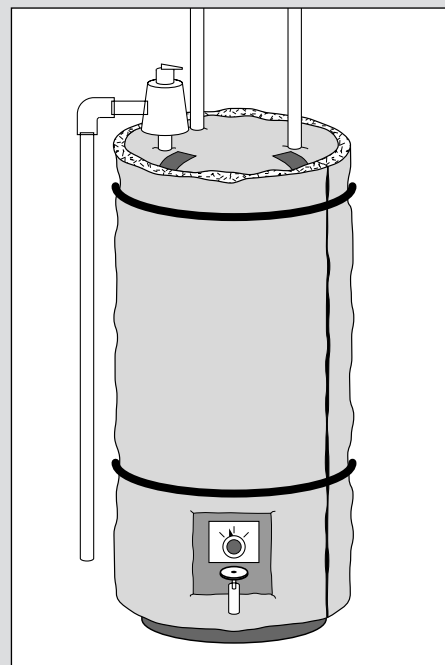

4

Source List

The following organizations and publications provide more information on hot-water energy efficiency. Much of the information included in this publication was obtained from several of these sources. This list does not cover all the available books, reports, and articles on hot-water energy efficiency, nor is the mention of any publication to be considered a recommendation or endorsement. To obtain the publications in this list, contact your local library or bookstore or the publisher. Check publication prices through your bookstore or the publisher before placing an order.

American Council for an Energy-Efficient Economy (ACEEE)

1001 Connecticut Avenue, NW, Suite 801
Washington, DC 20036
(202) 429-8873

or

2140 Shattuck Avenue, Suite 202
Berkeley, CA 94704

ACEEE provides general and technical information on energy efficiency, including these publications: *The Consumer Guide to Home Energy Savings*, *The Most Energy-Efficient Appliances*, and *Saving Energy and Money with Home Appliances*. These publications can be ordered by writing the ACEEE office in Berkeley, California.

Association of Home Appliance Manufacturers (AHAM)

Information Center
20 North Wacker Drive
Chicago, IL 60606
(312) 984-5800 ext. 315

AHAM provides energy efficiency information for specific brands of major appliances. The association also runs a certification program for certain types of appliances.

Gas Appliance Manufacturers Association, Inc. (GAMA)

1901 North Moore Street, Suite 1100
Arlington, VA 22209
(703) 525-9565

GAMA has information on residential gas appliances and equipment, electric and oil-fired water heaters, and oil-fired warm air furnaces.

U.S. Department of Energy

Energy Information Administration (EIA)
National Energy Information Center
EI-231, Room 1F-048
Forrestal Building
Washington, DC 20585
(202) 586-8800

EIA compiles a wide range of statistics for the energy professional on energy sources and energy consumption. EIA's *Household Energy and Consumption and Expenditures* contains information on residential energy use.

Further information about energy-efficient water heating can be obtained by contacting:

The Energy Efficiency and Renewable Energy Clearinghouse (EREC)

P.O. Box 3048
Merrifield, VA 22116
(800) 363-3732

EREC provides free general and technical information to the public on a wide spectrum of topics and technologies pertaining to energy efficiency and renewable energy.

Also contact your state and local government energy offices and utility for additional information on energy-efficient water heaters, installation, and rebate or incentive programs.

Reading List

Books and Reports

Consumer Reports 1992 Buying Guide Issue, Consumers Union of the United States, Inc., 101 Truman Avenue, Yonkers, NY 10703-1057, December 1991.

The Water Heater Workbook: A Hands-on Guide to Water Heaters, published by Elemental Enterprises, P.O. Box 928, Monterey, CA 93942, 1992.

"Water Heating," *Energy Edge*, Pennsylvania Energy Office, 116 Pine Street, Harrisburg, PA 17101 (printed by DOE).

Articles

"An Investigation of Off-Peak Domestic Hot Water Heating," *ASHRAE Journal*, p. 32, January 1990.

"Dishwashers," *Consumer Reports*, p. 637, October 1993.

"Hot Water Energy Conservation: Heating Water Accounts for 15% to 25% of an Average Family's Energy Budget," *Consumer's Research Magazine*, p. 19, January 1991.

"Safer Water Filters, Cheaper Water-Heating Systems, and More," *Home Mechanics*, p. 37, June 1993.

"Showering Them With Gas," *American Gas*, p. 22, April 1989.

